

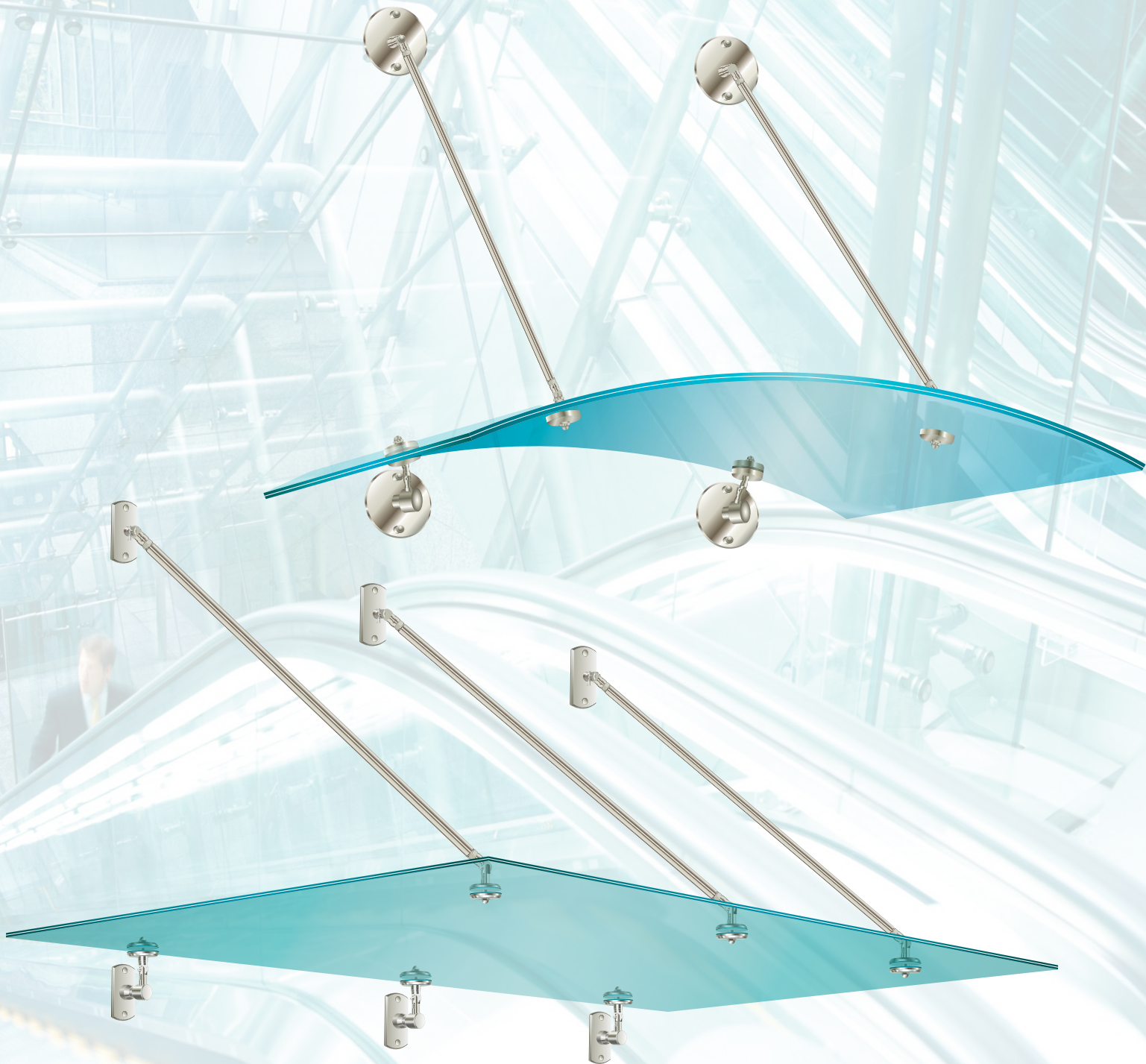

# Frameless Glass Canopy Systems

- For use Tempered Laminated Glass.
- All Stainless Steel Construction.

- Easy Installation Allows an Economical and Elegant Solution for both Commercial & Residential Applications.
- $\pm 5^\circ$  Adjustable Slope for most weather Conditions.



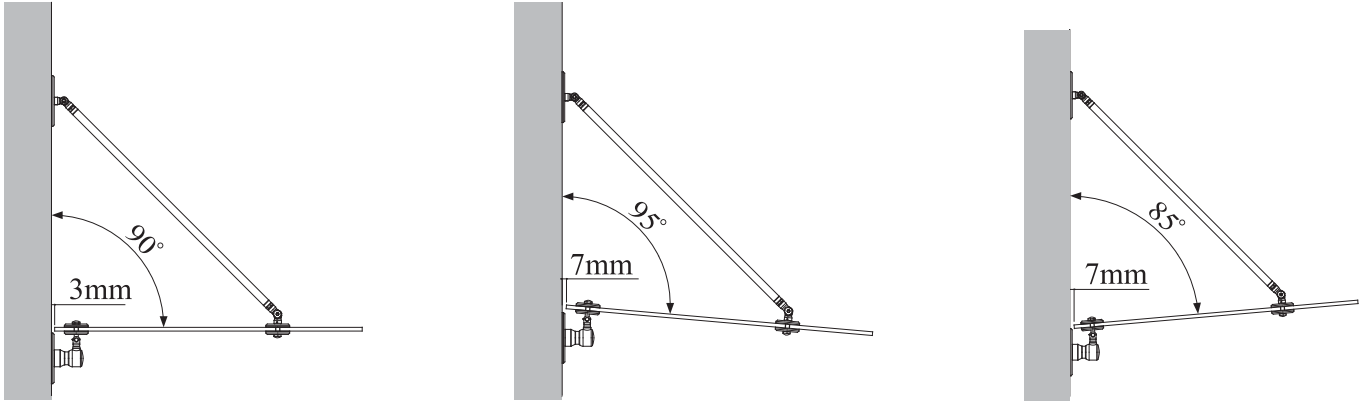

• The slope of the Glass Canopy can be adjusted  $\pm 5^\circ$  by revolving the connecting rod.

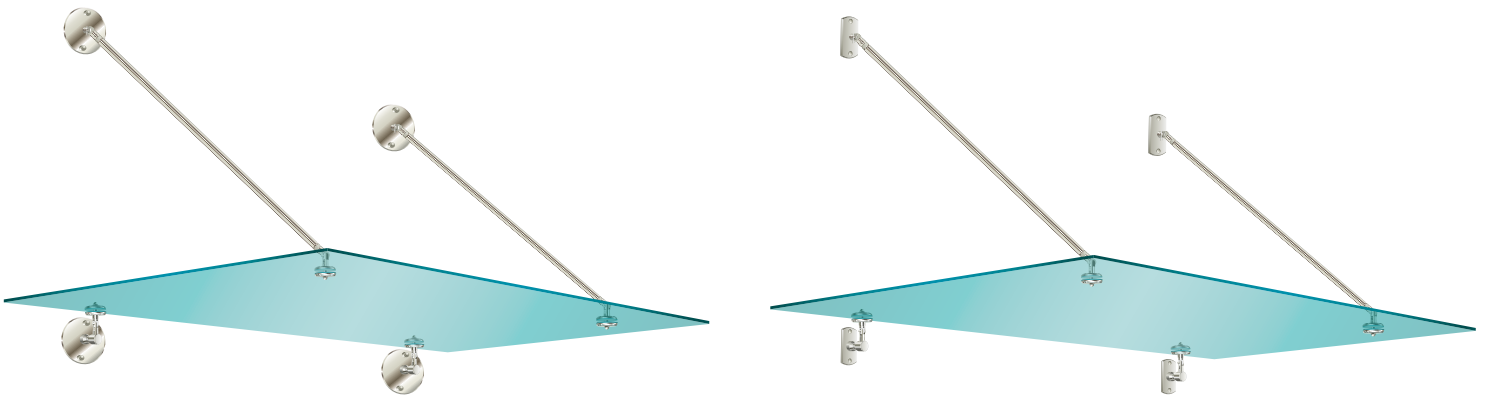

- Make-up of laminated glass panel
  - \*6+6mm or 8+8mm tempered glass with 1.5mm interlayer.
  - \*All glass panel edges should be polished.
- Use connecting rod (length adjustable +50mm)
  - Art. F10-1920-1
  - Art. F10-1920-2
  - Art. F10-1920-3

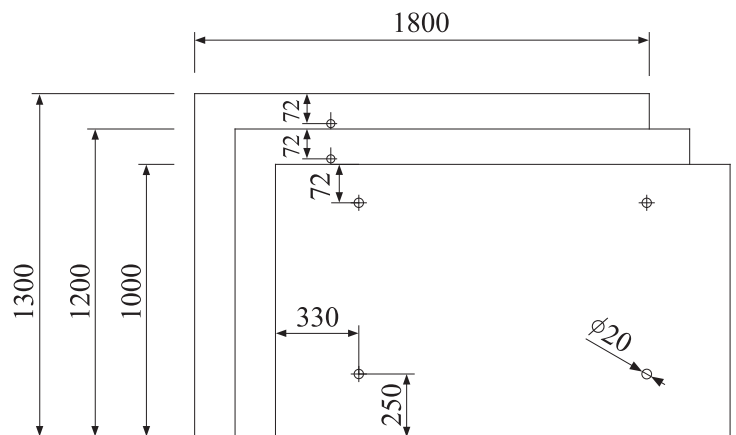
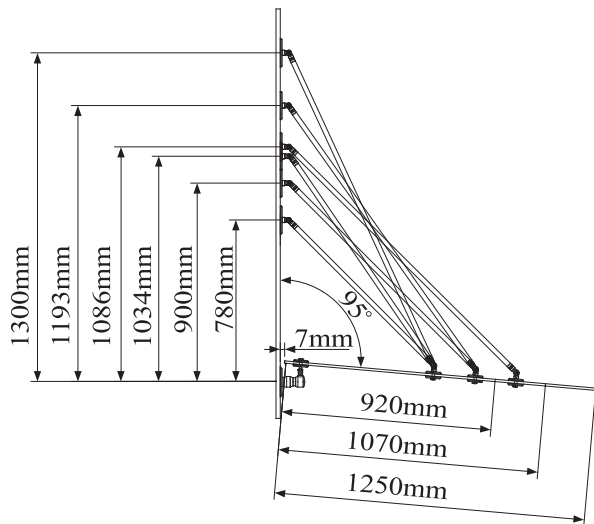
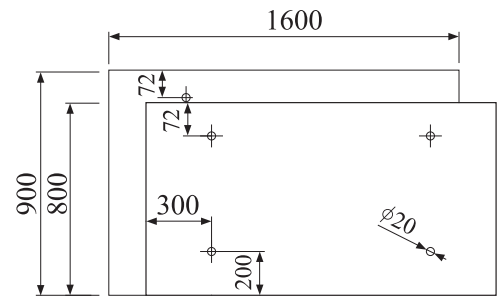

- Ues connecting rod.  
Art. F10-1920-3

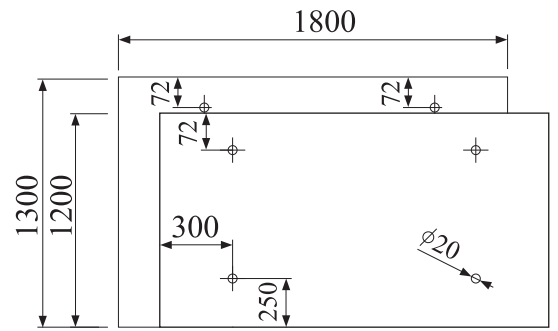
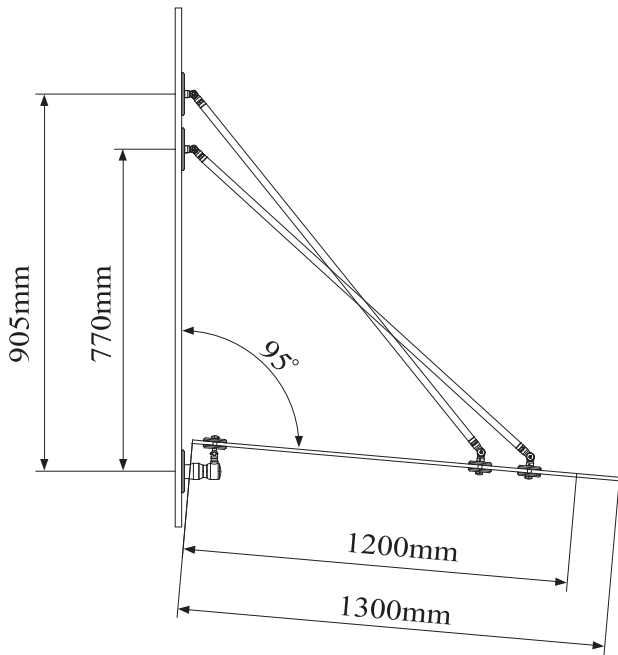





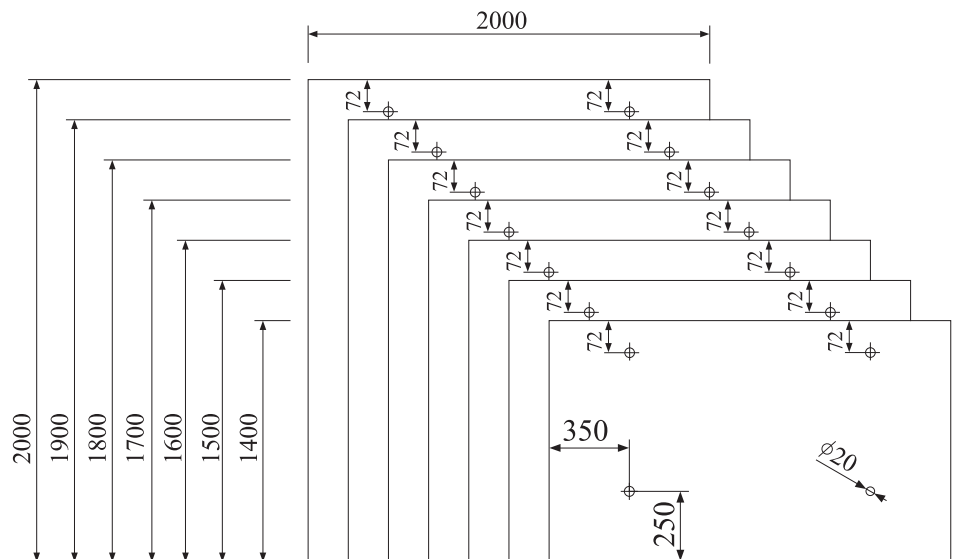
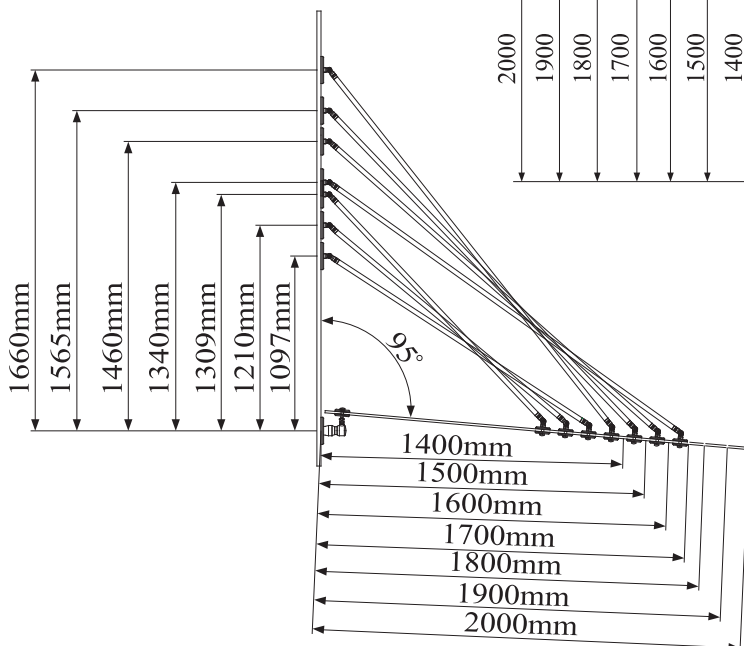





- Make-up of laminated glass panel:  
\* 10+10mm tempered glass with  
1.5mm interlayer

- Use connecting rod.  
Art. F10-1920-4  
Art. F10-1920-5

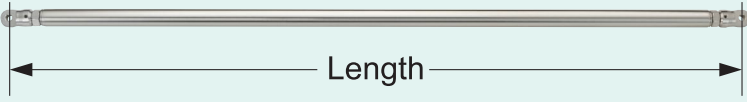

- Make-up of laminated glass panel:  
\* 10+10mm tempered glass with  
1.5mm interlayer

 <p><b>F10-1900 Mounting Kit</b></p> <ul style="list-style-type: none"> <li>• Contents: 1pc. of Top Plate.</li> <li>1pc. of Top Pivot.</li> <li>1pc. of Bottom Plate.</li> <li>1pc of Bottom Pivot.</li> </ul>		<b>F10-1910</b>	<b>Top Plate</b> ①
		<b>F10-1930</b>	<b>Top Pivot</b> ③
		<b>F10-1950</b>	<b>Bottom Plate</b> ⑤
		<b>F10-1940</b>	<b>Bottom Pivot</b> ④
 <p><b>F10-1900S Mounting Kit</b></p> <ul style="list-style-type: none"> <li>• Contents: 1pc. of Top Plate.</li> <li>1pc. of Top Pivot.</li> <li>1pc. of Bottom Plate.</li> <li>1pc of Bottom Pivot.</li> </ul>		<b>F10-1910S</b>	<b>Top Plate</b> ①
		<b>F10-1930</b>	<b>Top Pivot</b> ③
		<b>F10-1950S</b>	<b>Bottom Plate</b> ⑤
		<b>F10-1940</b>	<b>Bottom Pivot</b> ④
<p><b>F10-1920 Connecting Rod</b></p>  <p>920, 1070, 1250, 1620, 2100mm</p>	<b>920mm</b>	<b>F10-1920-1</b>	Each side can be adjusted for longer 25mm, both sides total can be 50mm longer. ②
	<b>1070mm</b>	<b>F10-1920-2</b>	- do - ②
	<b>1250mm</b>	<b>F10-1920-3</b>	- do - ②
	<b>1620mm</b>	<b>F10-1920-4</b>	- do - ②
	<b>2100mm</b>	<b>F10-1920-5</b>	- do - ②

**Note:**

- Glass Panel & Stainless Steel Mounting Screws are not included.
- All components are made by high grade Stainless Steel.