



# Glass to Glass - 2 Ways

## Hole Pitch of Connecting Bar

	52.5	60	82	103
	Hole Center to Glass Edge			
Angle	A/B	A/B	A/B	A/B
90°	75	80	96	
95°	70	75	90	
100°	66	71	85	
105°	62	67	81	
110°	59	63	77	
115°	55	60	73	
120°	52	56	69	
125°	49	54	66	
130°	47	51	63	
135°	44	48	60	
180°	25	28.5	39.5	50

unit:mm

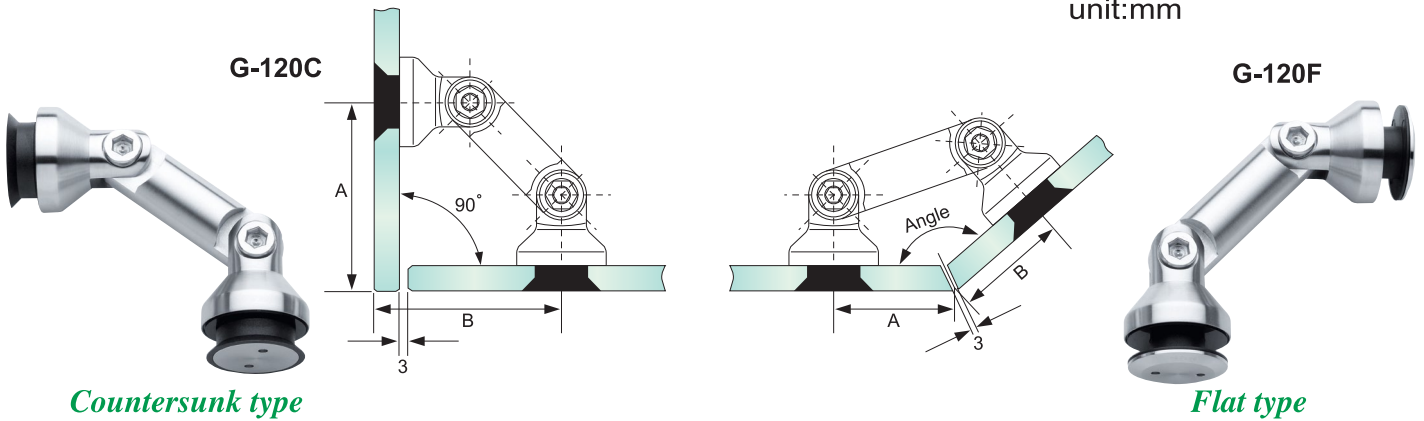

# Glass to Glass - 3 Ways

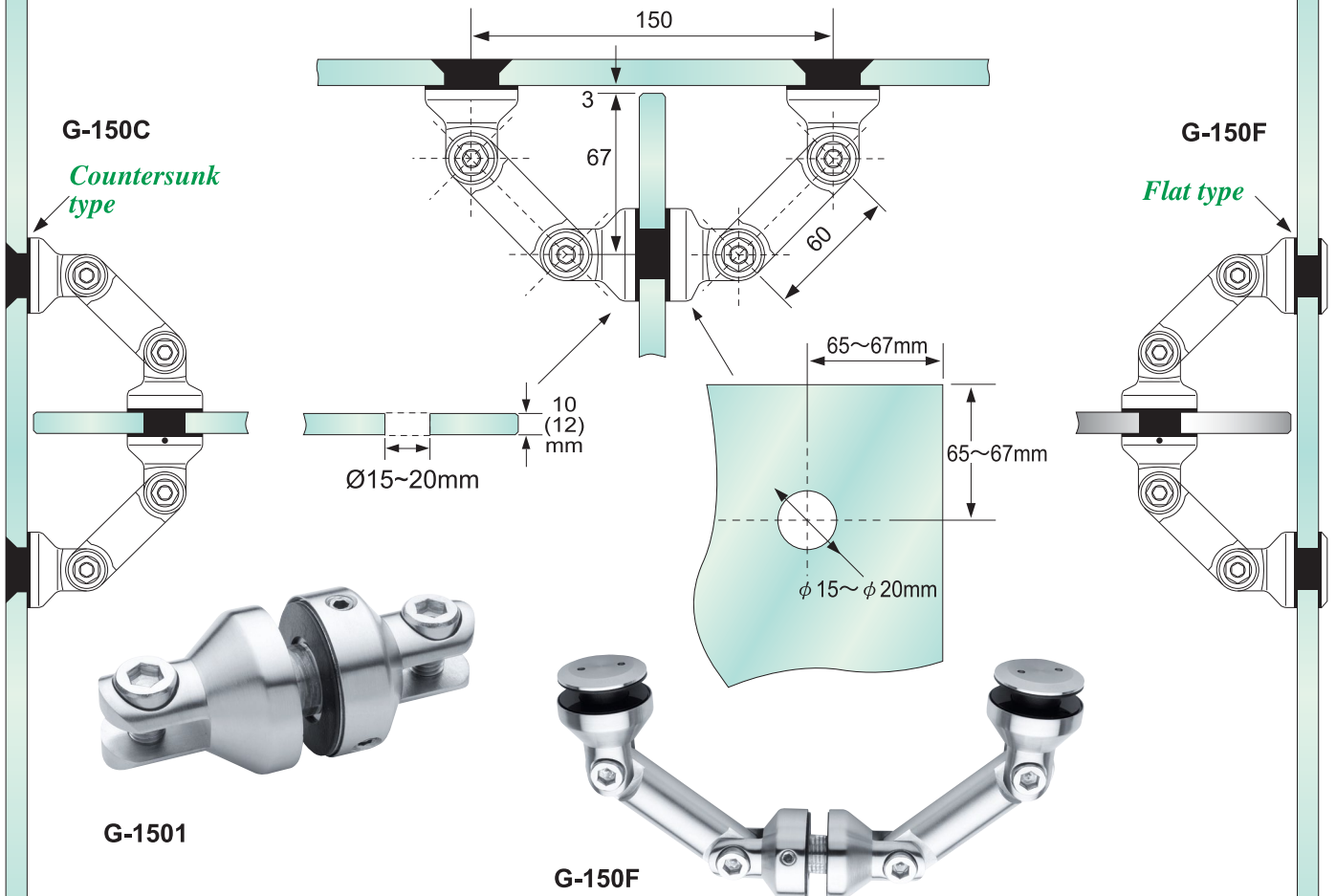

## Glass to Wall



G-1391

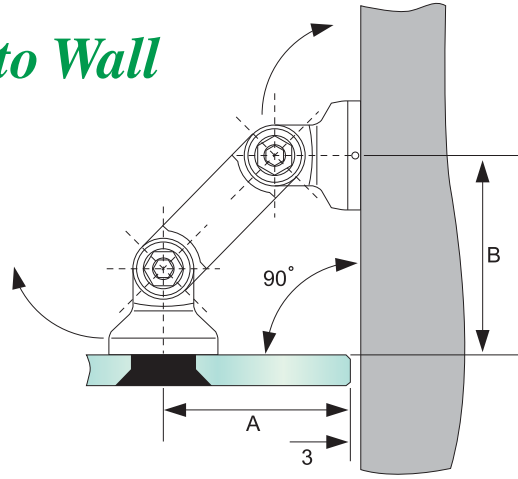

G-139C

Countersunk type

Hole Pitch of Connecting Bar						
Hole Center to Glass Edge						
Angle	52.5		60		82	
	A	B	A	B	A	B
90°	67	62	72	67	88	83



G-139F

Flat type

## Glass to Ground / Ceiling

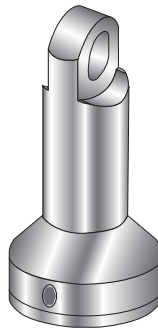
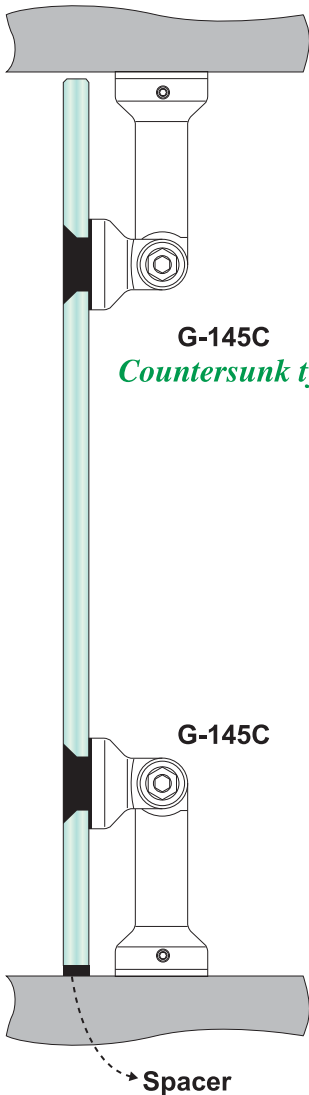

G-1451

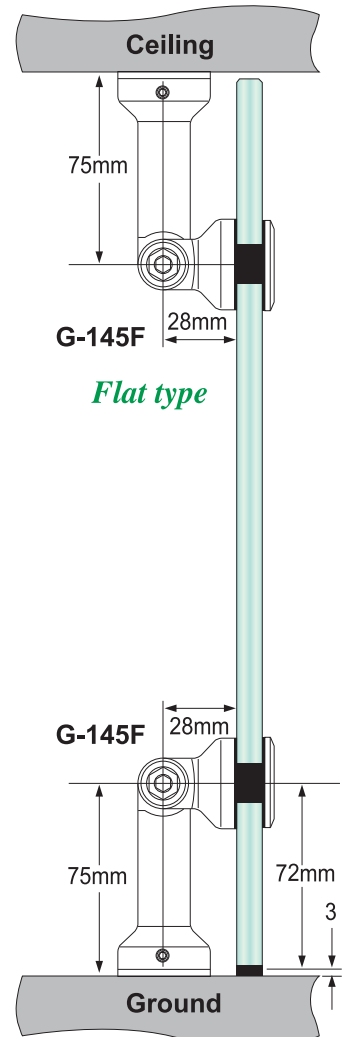

G-145C



G-145F

## G-1201C

### Single Point Fitting

\* Countersunk type



## G-1201F

### Single Point Fitting

\* Flat type

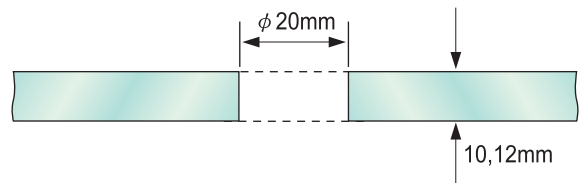
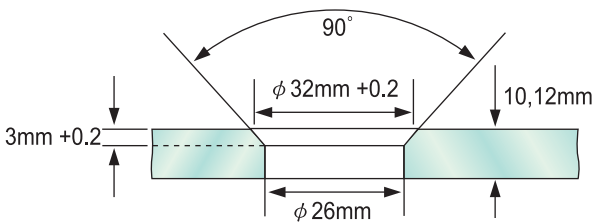

## Connecting Bar

\* For Connect fitting to glass or to wall.

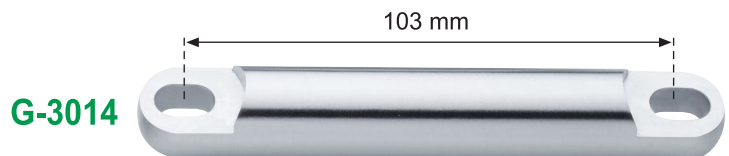
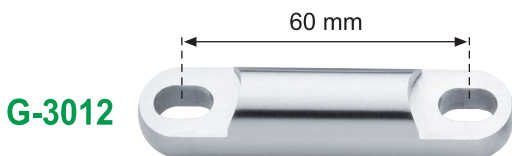
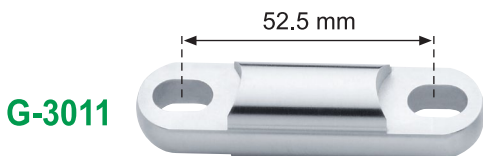

## Single Point Fitting

- \* Straight to the Point of glass & wall.
- \* Left & right, up & down and level adjustable to uneven wall.

### G-102C

\* Countersunk type

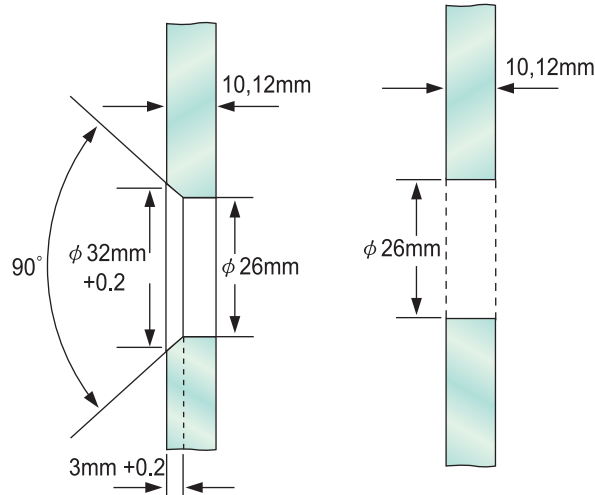

### G-102F

\* Flat type

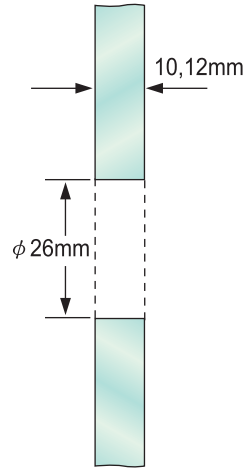

## Single Point Fitting

- \* Straight to the Point of glass & wall
- \* Left & right, up & down adjustable.

### G-102SC

\* Countersunk type

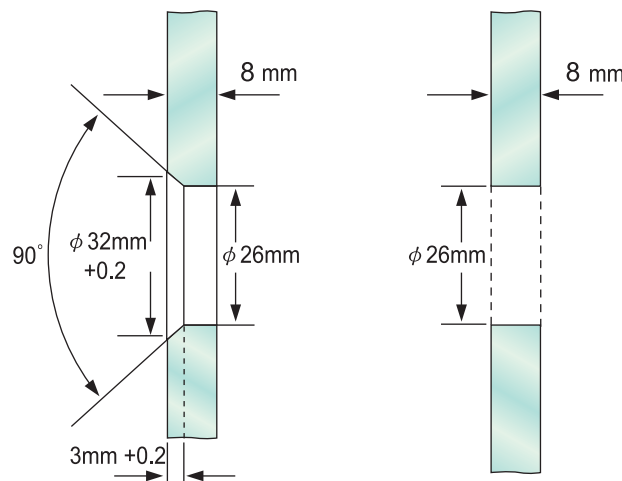

### G-102SF

\* Flat type

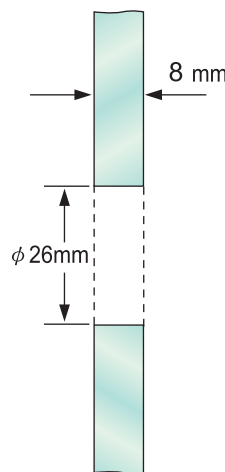





In the field of architectural fittings for glass doors high quality and total design flexibility are essential for ease of installation, safety and functionality.

**GCC** full range of fittings are aesthetically designed and manufactured to provide practicality and security to tempered glass assemblies.

**GCC** will be happy to help your special design requirements, for any doubts, please contact your nearest **GCC** distributors for any technical assistance on parts and services, or contact us directly.

**GCC** reserves all rights to make product modifications or engineering changes without notification.



**PGF**  
Prestige Glass Fittings

Unit 8/3 Selgar Ave  
Clovelly Park, SA 5042

**Phone:** 0429 933 583

**Email:** [sales@prestigeglassfittings.com.au](mailto:sales@prestigeglassfittings.com.au)

**Web:** [www.prestigeglassfittings.com.au](http://www.prestigeglassfittings.com.au)

**Notes:**